

# ENSTROM 480B

## SPECIFICATIONS AND PERFORMAMCE DATA

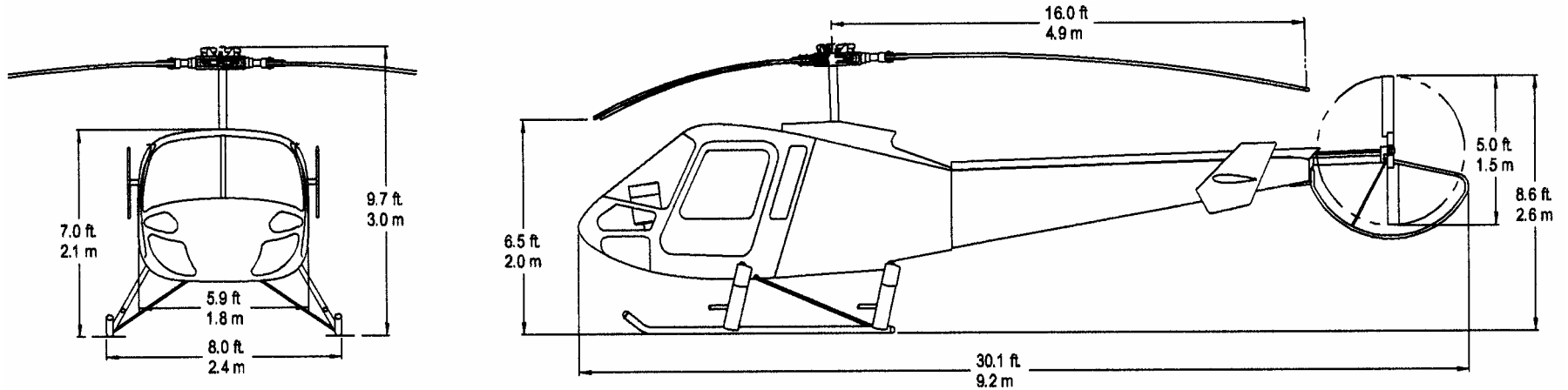

### SPECIFICATIONS

#### WEIGHTS

Gross Weight	3,000 lbs	1,361 kg
Empty Weight (Std. Equip.)	1,820 lbs	826 kg
Useful Load	1,180 lbs	535 kg

#### FUEL SYSTEM

2 Interconnected Tanks	90 gal	341 lit
------------------------	--------	---------

#### POWER PLANT

Rolls-Royce 250-C20W Turbine		
Power Available	420 shp	313 kw
Maximum (5 Min.)	305 shp	227 kw
Continuous	277 shp	206 kw
Particle Separator		93% Eff

### PERFORMANCE (STANDARD DAY)

#### MISSION WEIGHTS

	<u>2,500 lbs</u>	<u>2,800 lbs</u>	<u>3,000 lbs</u>
Never Exceed Speed	125 kts	125 kts	124 kts
Maximum Cruise Speed (TAS @ 3,000 ft.)	115 kts	113 kts	109 kts
Service Ceiling	13,000 ft	13,000 ft	10,000 ft
Maximum Rate of Climb @ SL	1,600 fpm	1,475 fpm	1,375 fpm
Hover Ceilings			
In Ground Effect (IGE)	15,600 ft	13,000 ft	12,300 ft
Out of Ground Effect (OGE)	14,000 ft	10,600 ft	5,400 ft
Range and Endurance (No Reserve)			
Maximum Range @ 3,000 ft.	370 NM	360 NM	355 NM
Maximum Endurance @ 3,000 ft.	4.7 hrs	4.6 hrs	4.5 hrs